

Product Information
01/2011

Flexible connectors - Solderless terminals - Contact systems

druseidt
Elektrotechnik

„druseidt-Titan“
High current contact systems
and cleaning devices

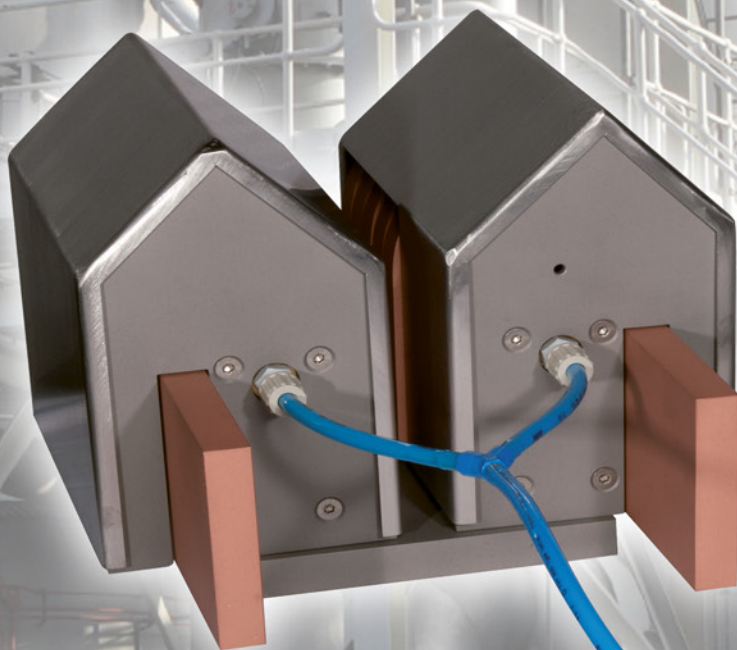

Edition: 10/2023 (Info 01/2011)

Paul Druseidt
Elektrotechnische Spezialfabrik GmbH & Co. KG
Neuenkamper Str. 105
42855 Remscheid, Germany

Telephone: +49 (21 91) 93 52-0
Telefax: +49 (21 91) 93 52-150
http: www.druseidt.de
E-Mail: info@druseidt.de

The use of photos, drawings or other parts of this catalogue for own advertisement or other usage is subject to our formerly written acceptance.

„druseidt-Titan“ with a hydro-pneumatically activated drive the innovative and inimitably high current contact system for anodizing and electroplating plants

The development of this new contact system, called Titan, based on the fact that the electrical contact resistance will be reduced when working with a higher contact pressure.

Therefore we equipped our new contact system with a novel force booster which realize a constant pressure up to some thousands Newton per contact finger by working with a special hydro-pneumatic power gear ration.

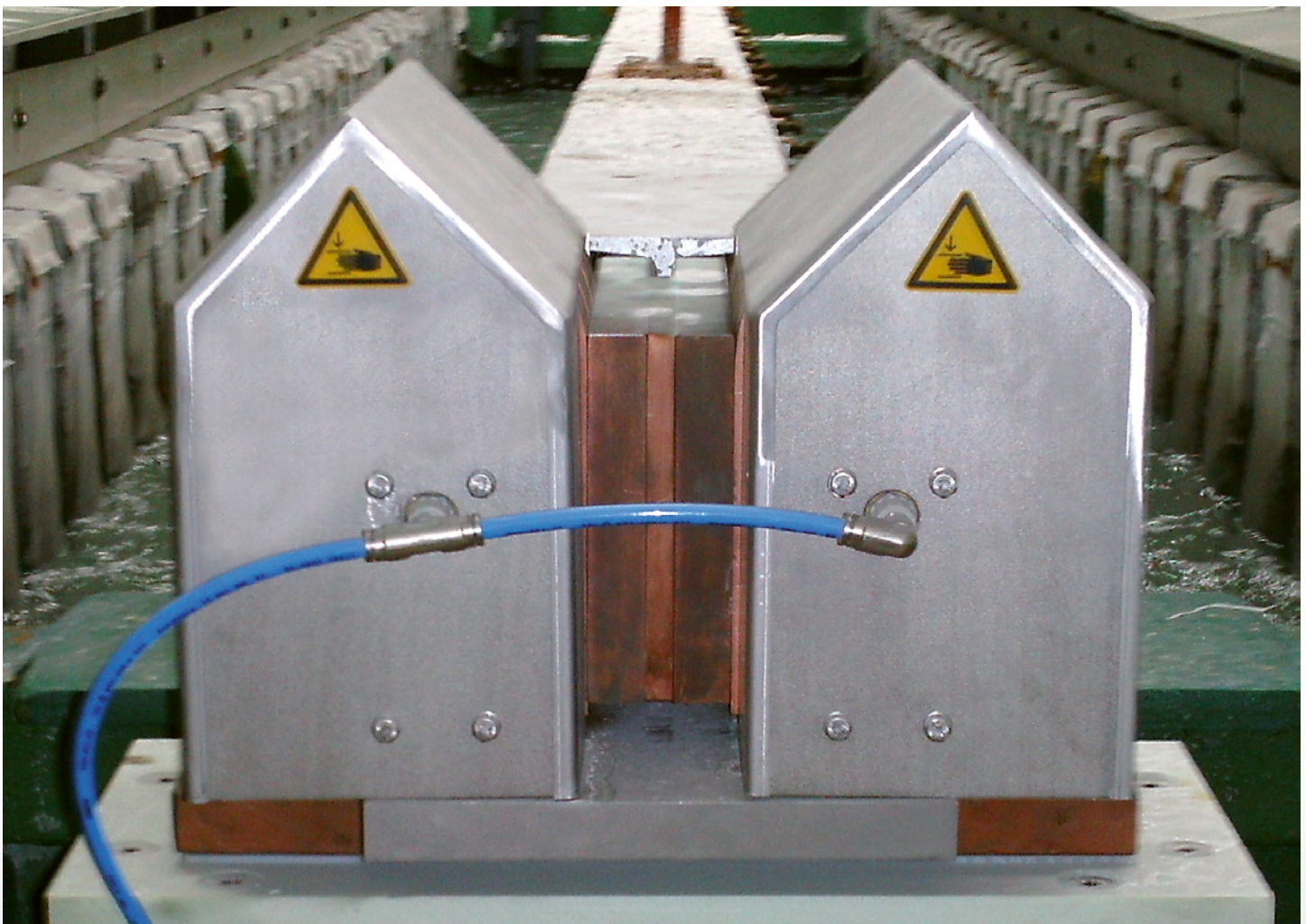

High current contact-saddles „druseidt-Titan“ a perfect system for perfect application

Theoretical foundations to the subject contact resistance

The quality of an electrical connection depends on the material, the cross-section, the dimension and the finishing of the contact areas as well as on the contact pressure. Such facts define the electrical contact resistance and finally the operation and life time of the connection. So when working with a higher contact pressure the electrical resistance will be reduced.

The System Titan

When working with normal movable finger-contacts the contact pressure is defined by the material thickness of the used springs and achieves values of ca. 200 N per contact-finger. This value can be increased of more than 1000 N per complete contact when working with standardized pneumatically activated contacts. When developing our new system Titan our intention was to increase the contact pressure in a way that the clamp-connection can be compared with the values of a screw-connection according to the German DIN directives. All contacts of the Titan system are equipped with pluggable protective covers made out of stainless steel. The pluggable construction enables an easy and uncomplicated controlling and cleaning procedure. So a costly demounting of the contacts or the protective covers is not necessary.

The soiling problem

Soiling problems are beside the fact of to low contact forces one of the main problems inside of electroplating and anodizing plants. An increased high contact resistance and electrical contact problems are often the consequences of soiling. High power losses and high temperature rises of the contact-saddles are the results. The worst case could be costly repairs, coating problems and longer down-times of the plants. In order to offer solutions and improvements relating to the soiling problems of electrical contact surfaces we developed new cleaning systems and cleaning devices too. In combination with our contact system Titan we offer so important solutions for a further process optimization.

The hydro-pneumatically drive

The contact-fingers of the Titan system are operated by a special hydro-pneumatically activated force-booster. This new developed force-booster dissipates the incoming air pressure into a very high contact pressure by a hydraulic system. The installed hydraulic system is actuated with water and do not need any form of oil. So is by a leakage a contamination of the plating tanks absolutely impossible. All sealing elements are tested over a long period and are designed in compliance with the specific demands of the electroplating and anodizing industry.

Economically advantages

- extensive reduction of the contact resistance compared with traditional contact systems
- extensive reduction of electrical losses and optimizing of the process cycles
- reduction of costly repairs
- reduction of system down-times
- modular designed contacts and different standardized models enable a customized adjustment into different plants and installation situations
- all contacts up to a current load of 6000 A are equipped with special movable contact-fingers which allow to work with bus-bars with a thickness difference of 10 mm without any changing or rebuilding of contact parts
- long life quality „Made in Germany“

A minimized contact resistance
through a all time high contact pressure

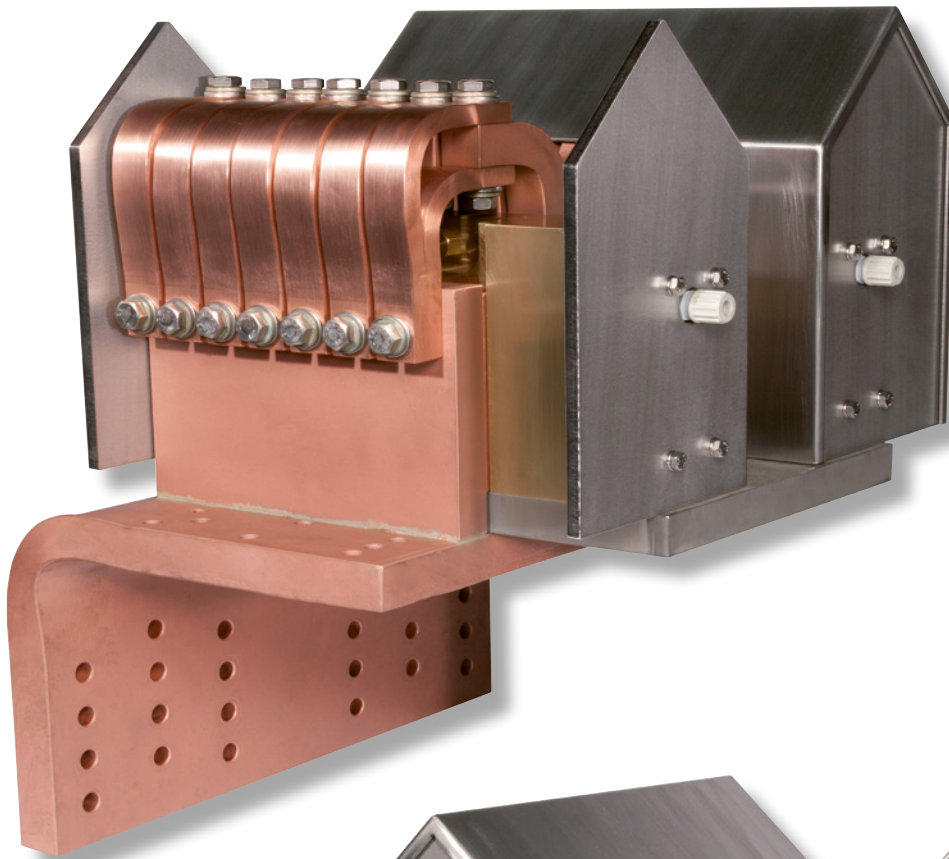

- Standardized models in a current range 3000 A up to 15000 A
- Models up from 6000 A with special movable contact fingers with measurement compensation
- contacts in special design for extremely high current > 15000 A
- Self cleaning effect, because the contact surfaces are rubbed clean when the bars are inserted



„druseidt-Titan“ –
standard design

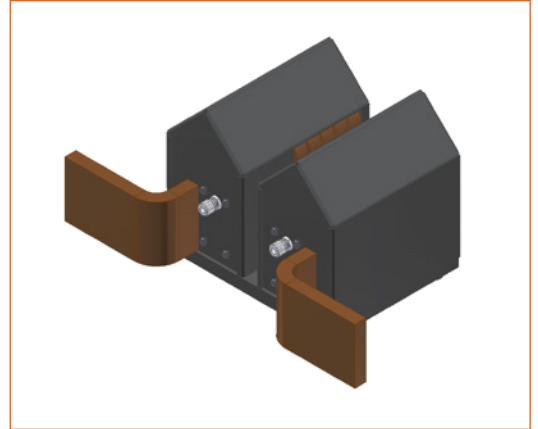
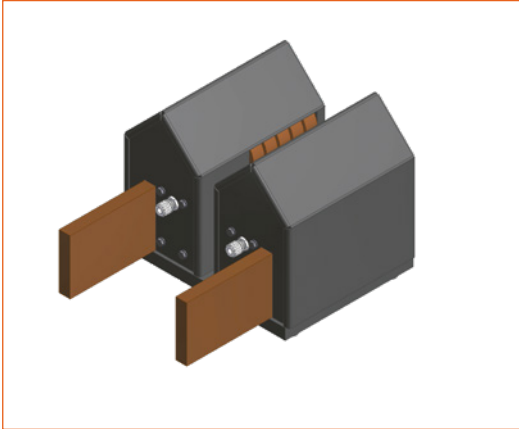

current load	Part-No.		Part-No.
3000 A	25050		25350
4000 A	25051		25351
5000 A	25052		25352
6000 A	-		-
8000 A	-		-
10000 A	-		-
12000 A	-		-
15000 A	-		-

Hydro-pneumatically activated contact series

„druseidt-Titan“

current load 3000 A - 5000 A

System description

Equipped with a force booster working with a special water actuated hydro-pneumatic power gear ration. Contact pressure according to the following diagram. All contact fingers are individual activated so that they abut on the bus-bars stable and safe. They are mounted in a way that their contact surfaces are rubbed clean when the bus-bars are inserted. Pluggable protective covers made out of stainless steel are standard. Optional with or without temperature sensor Pt 100. For the absorption of the extremely high contact forces all contacts are mounted on a stabilized stainless steel plate.

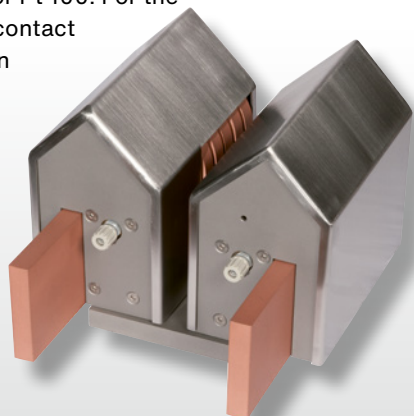

Deliverable design

To connect the contact-saddles with the bus-bar system you do not need any form of flexible connectors. The connection can be done by using massive bars. Connection possibilities according to type 1 – type 4 as per above mentioned drawings.

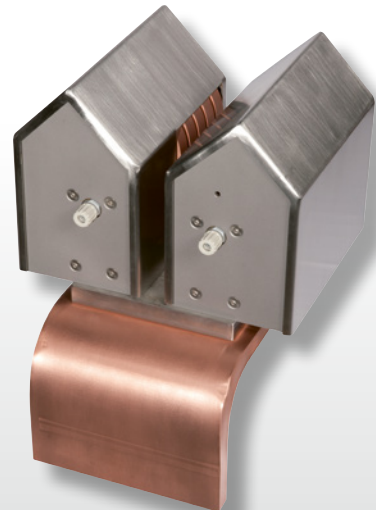

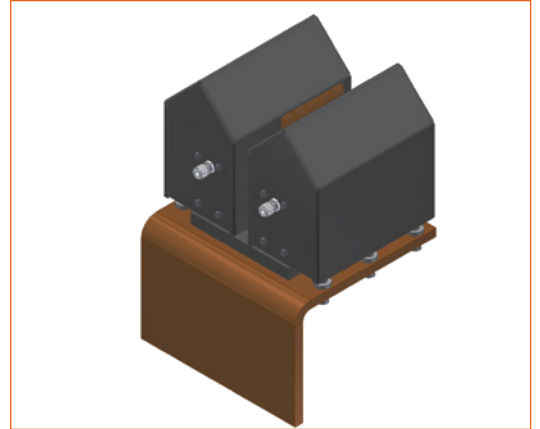
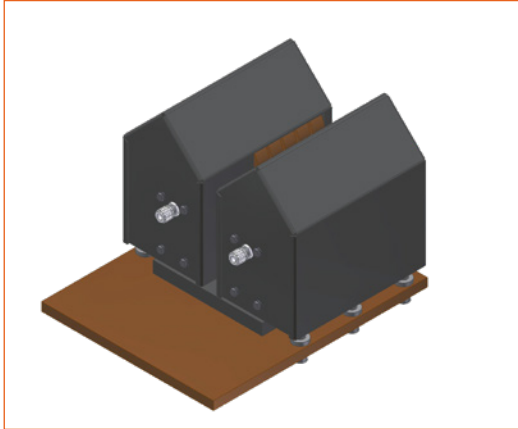

Part-No.	Part-No.
25150	25250
25151	25251
25152	25252
25153/25553	25253/25653
25154/25554	25254/25654
25155/25555	25255/25655
25156/25556	25256/25656
25157/25557	25257/25657

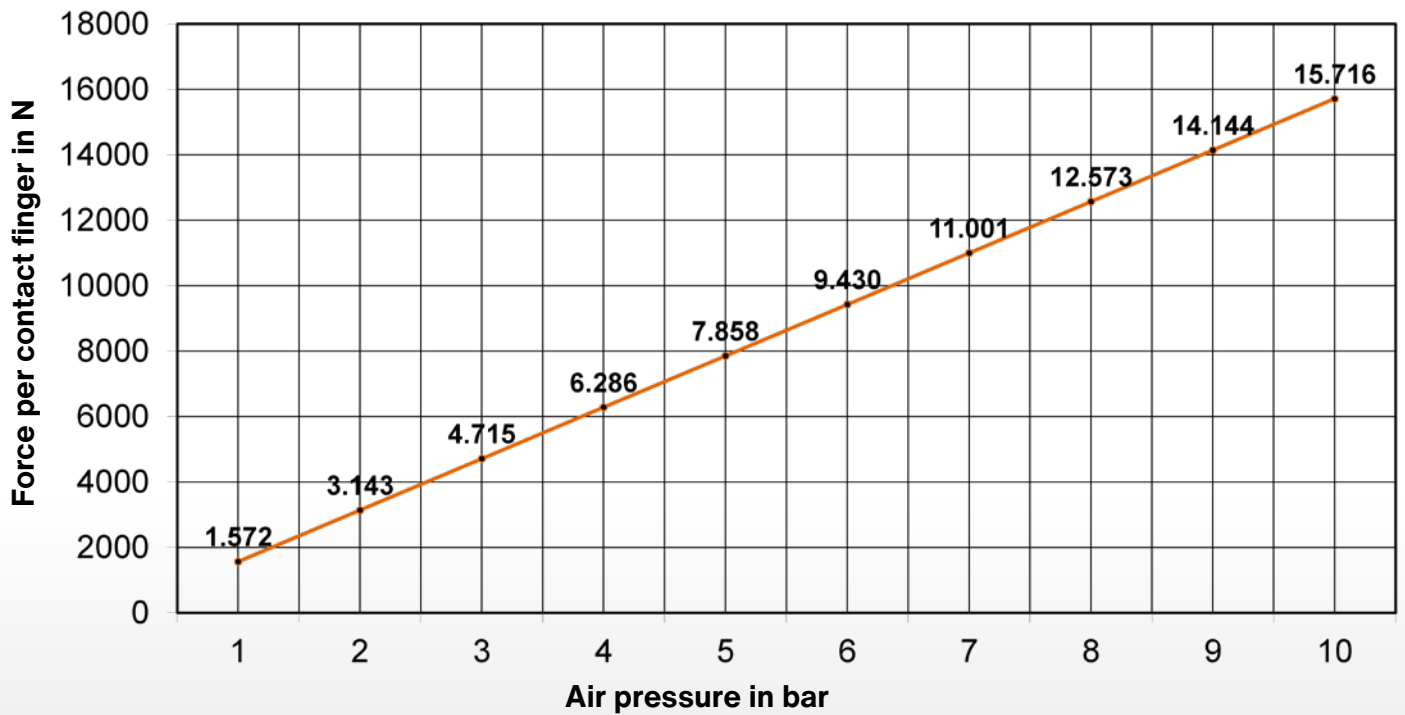

By an air pressure of 6 bar the total contact pressure of one complete contact-saddle achieve the following values:
 design model 3000 A = ca. 56,5 kN
 design model 4000 A = ca. 75,5 kN
 design model 5000 A = ca. 94,3 kN

Hydro-pneumatically activated contact series

„druseidt-Titan“

current load 3000 A - 5000 A

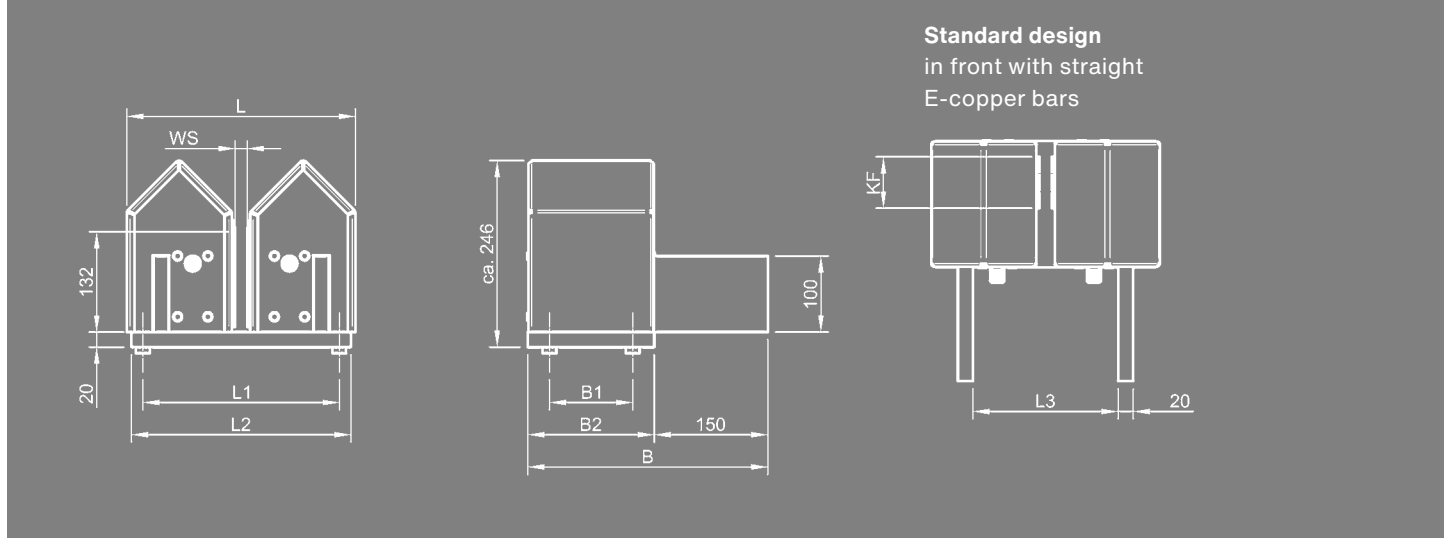

Part-No.	current load	dimensions mm								weight
		L	L1	L2	L3	B	B1	B2	KF	
25050	3000 A	302	260	290	192	317	110	167	68	48 kg
25051	4000 A	302	260	290	192	359	150	209	92	58 kg
25052	5000 A	302	260	290	192	383	180	233	116	65 kg

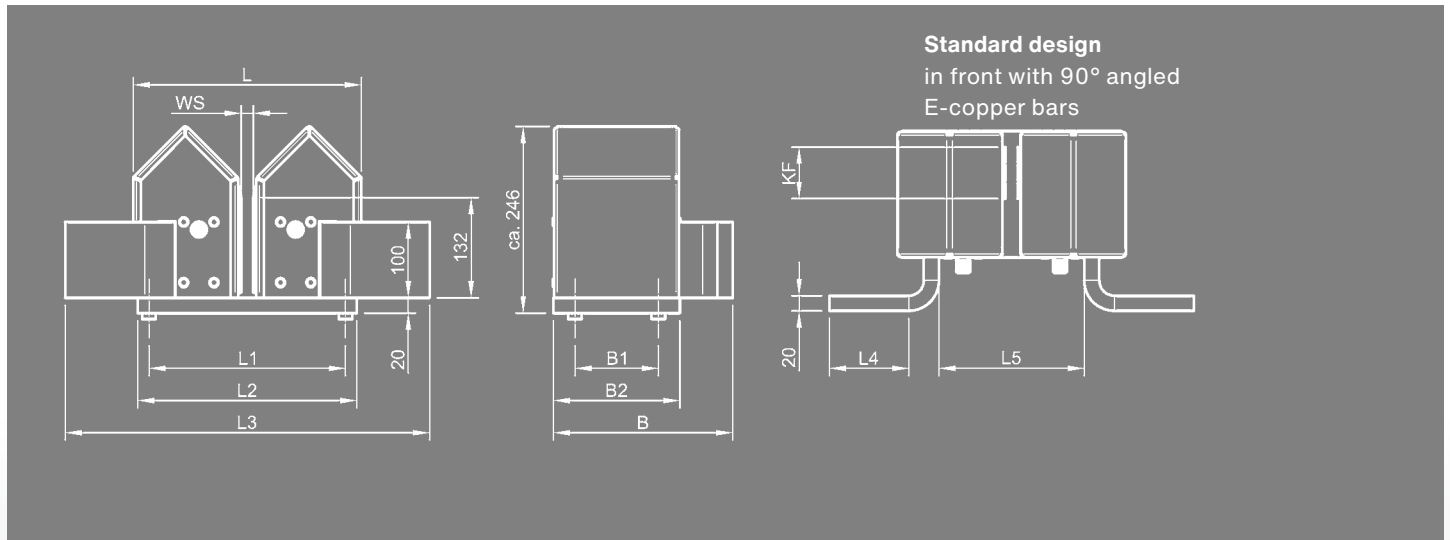

Part-No.	current load	dimensions mm										weight
		L	L1	L2	L3	L4	L5	B	B1	B2	KF	
25350	3000 A	302	260	290	482	105	192	237	110	167	68	49 kg
25351	4000 A	302	260	290	482	105	192	279	150	209	92	59 kg
25352	5000 A	302	260	290	522	125	192	303	180	233	116	67 kg

The values in the tables based on a bus-bar thickness of 20 mm. When working with differing bars please notice that the width of the contact-saddles will be accordingly changed. Minimum height of the bus-bars 60/80 mm. When working with a height of 60 mm or less than 80 mm it is necessary to mount a equalizing piece in the middle of the contact-saddle. On demand all contact-saddles are deliverable with an additionally mounted temperature sensor Pt 100.

Hydro-pneumatically activated contact series

„druseidt-Titan“

current load 3000 A - 5000 A

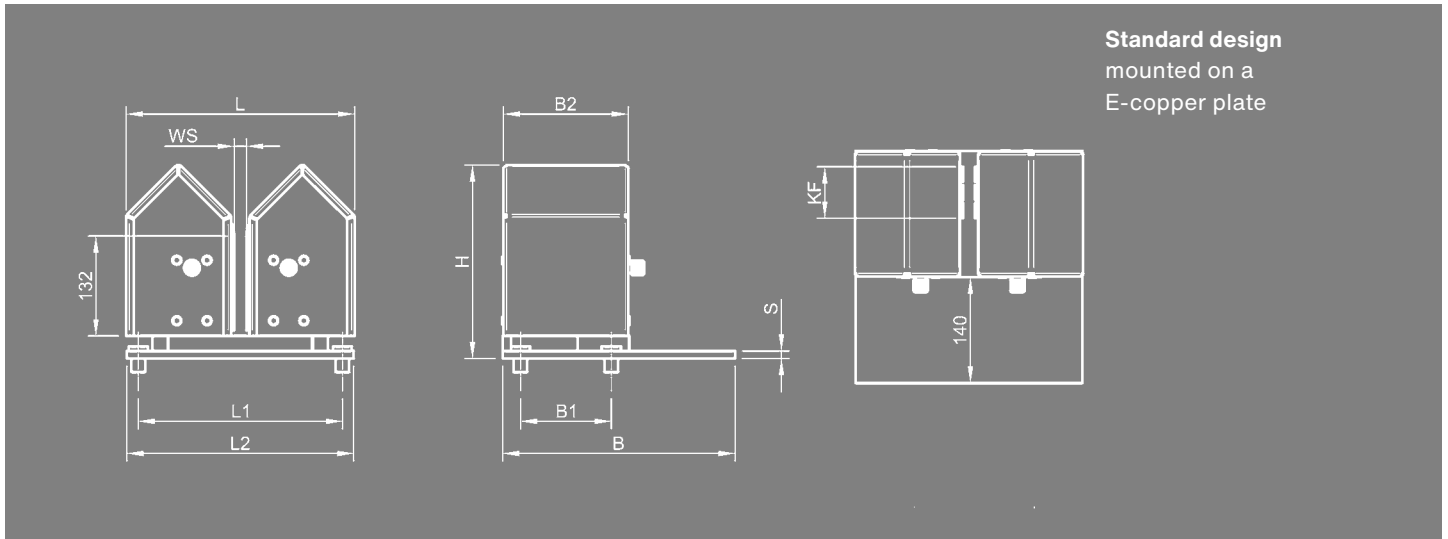

Part-No.	current load	dimensions mm									weight
		L	L1	L2	B	B1	B2	H	S	KF	
25150	3000 A	302	270	300	307	120	165	256	10	68	46 kg
25151	4000 A	302	270	300	349	2 x 80	207	258	12	92	58 kg
25152	5000 A	302	270	300	373	2 x 90	231	261	15	116	68 kg

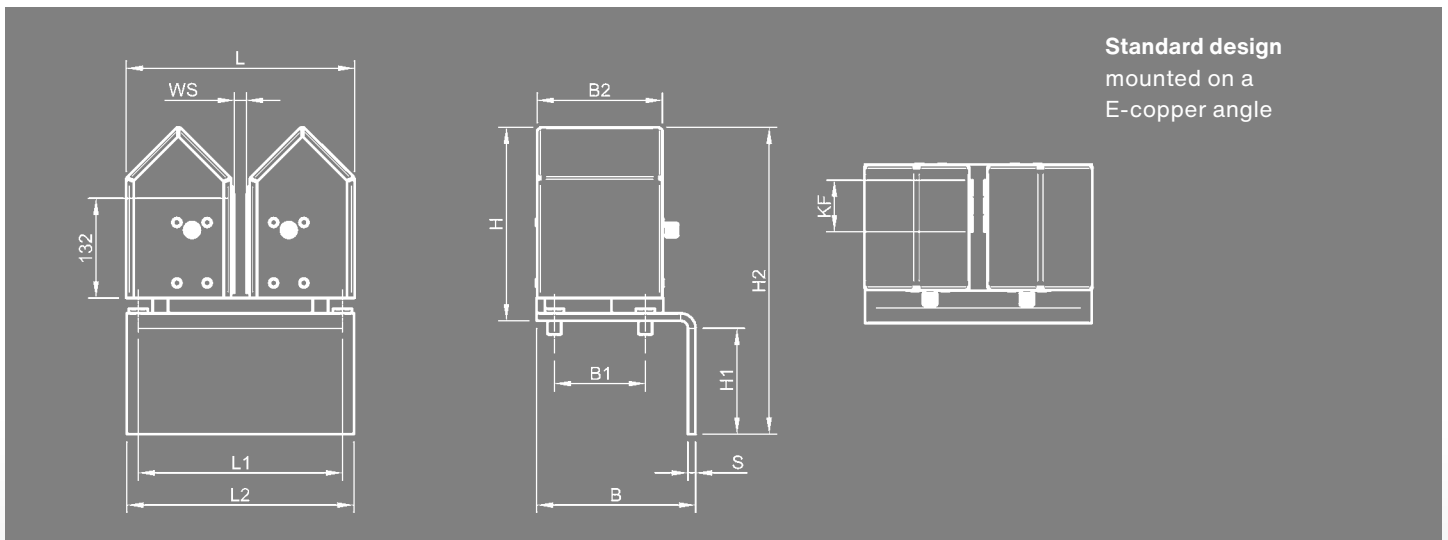

Part-No.	current load	dimensions mm											weight
		L	L1	L2	B	B1	B2	H	H1	H2	S	KF	
25250	3000 A	302	270	300	210	120	165	256	140	406	10	68	47 kg
25251	4000 A	302	270	300	250	2 x 80	207	258	136	406	12	92	59 kg
25252	5000 A	302	270	300	275	2 x 90	231	261	170	446	15	116	71 kg

The values in the tables based on a bus-bar thickness of 20 mm. When working with differing bars please notice that the width of the contact-saddles will be accordingly changed. Minimum height of the bus-bars 60/80 mm. When working with a height of 60 mm or less than 80 mm it is necessary to mount a equalizing piece in the middle of the contact-saddle. On demand all contact saddles are deliverable with an additionally mounted temperature sensor Pt 100.

Hydro-pneumatically activated contact series

„druseidt-Titan“

with measurement compensation, current load 6000 A – 15000 A

System description and deliverable design

Equipped with a force booster working with a special water actuated hydro pneumatic power gear ratio. Contact pressure in dependence of the air pressure to the following diagram. All contact fingers are individual activated and are movable in a way which allow to work with bus-bars which have a thickness difference of 10 mm without a changing or rebuilding of contact parts. So it is possible to work with in the contact area damaged or bent bars too. The contact fingers which are rubbed clean when the bus-bars are inserted, squeeze all bars stable and safe.

Pluggable protective covers made out of stainless steel are standard. Optional with or without temperature sensor Pt 100. For the absorption of the extremely high contact forces all contacts are mounted on a stabilized stainless steel plate. To connect the contacts with the bus-bar-system you do not need any form of flexible connectors. The connection can be done by using massive bars. For mounting contacts also into small places we offer additionally to the standard design separate models in compact design.

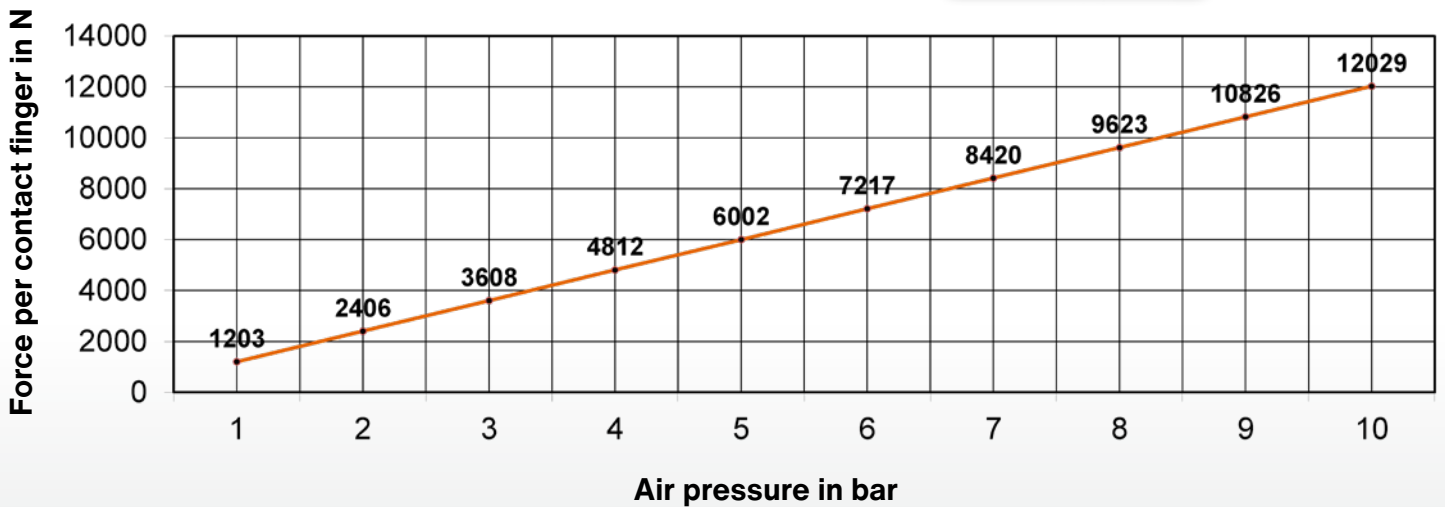

By an air pressure of 6 bar the total contact pressure of one complete contact-saddle achieve the following values:

- Design model 6000 A = ca. 57,7 kN
- Design model 8000 A = ca. 72,2 kN
- Design model 10000 A = ca. 101,0 kN
- Design model 12000 A = ca. 115,5 kN
- Design model 15000 A = ca. 144,3 kN

Hydro-pneumatically activated contact series

„druseidt-Titan“

with 10 mm measurement compensation, current load 6000 A – 15000 A

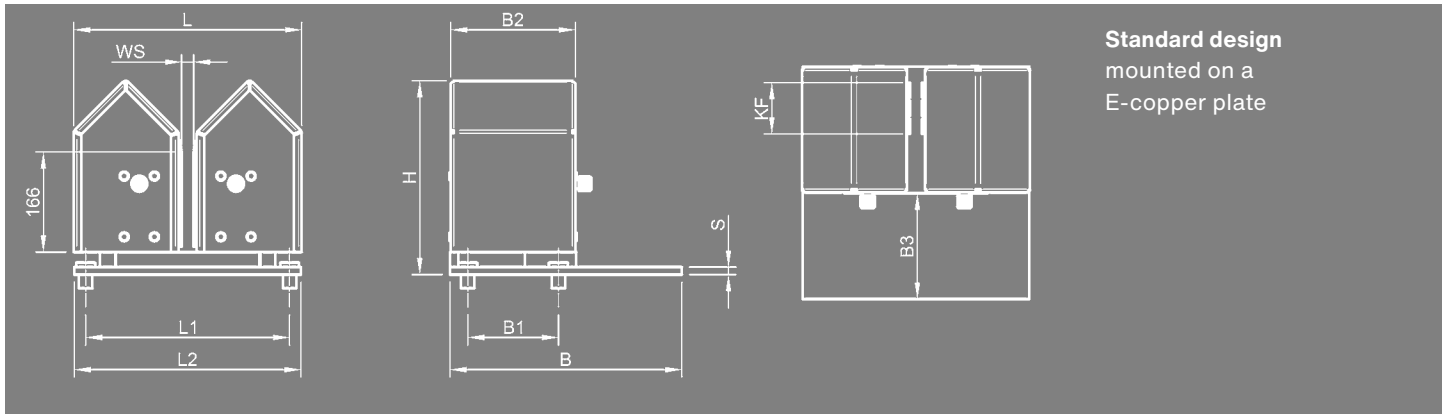

Part-No.	current load	dimensions mm										weight
		L	L1	L2	B	B1	B2	B3	H	S	KF	
25153	6000 A	346	285	320	410	2 x 90	228	180	318	15	112	96 kg
25154	8000 A	346	285	320	439	2 x 110	257	180	323	20	141	115 kg
25155	10000 A	346	285	320	549	2 x 145	337	210	328	25	199	156 kg
25156	12000 A	346	285	320	578	2 x 160	366	210	338	30	228	181 kg
25157	15000 A	346	285	320	652	3 x 230	440	210	343	35	286	211 kg

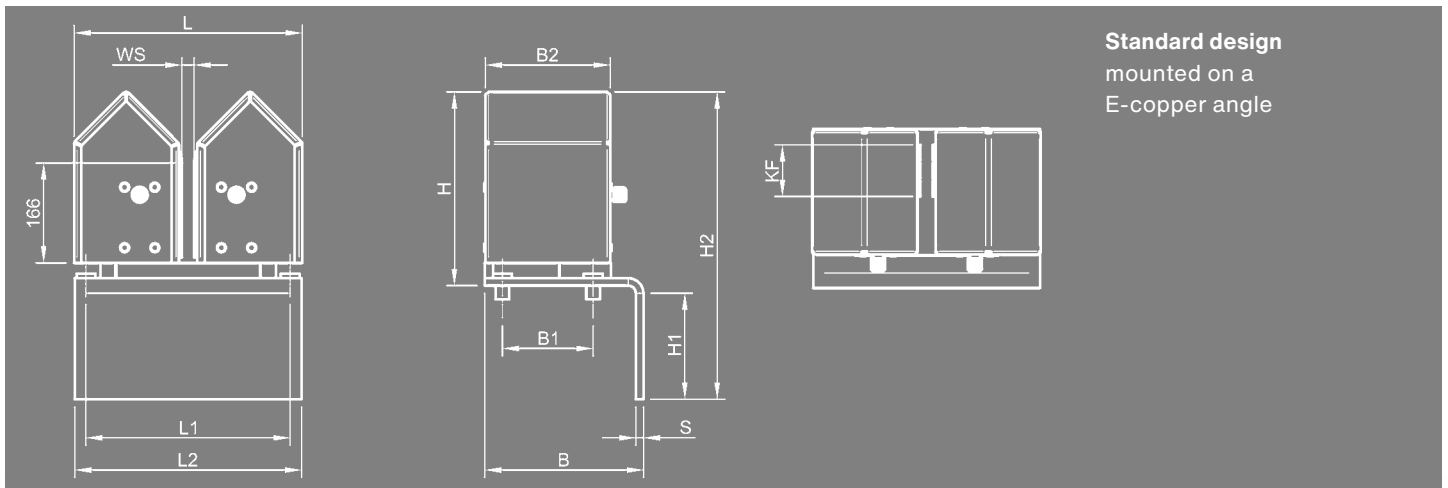

Part-No.	current load	dimensions mm											weight
		L	L1	L2	B	B1	B2	H	H1	H2	S	KF	
25253	6000 A	346	285	320	270	2 x 90	228	318	170	503	15	112	97 kg
25254	8000 A	346	285	320	320	2 x 110	257	323	170	513	20	141	118 kg
25255	10000 A	346	285	320	400	2 x 145	337	328	210	563	25	199	161 kg
25256	12000 A	346	285	320	440	2 x 160	366	338	210	578	30	228	188 kg
25257	15000 A	346	285	320	520	3 x 130	440	343	210	588	35	286	220 kg

The values in the tables based on a bus-bar thickness of 20 mm. When working with differing bars please notice that the width of the contact-saddles and if applicable the thickness of the E-copper plate or angle will be accordingly changed. Minimum height of the bus-bars 80/120 mm. When working with a height of 80 mm or less than 120 mm it is necessary to mount an equalizing piece in the middle of the contact-saddle. On demand all contact-saddles are deliverable with an additionally mounted temperature sensor Pt 100.

Hydro-pneumatically activated contact series

„druseidt-Titan“

with 10 mm measurement compensation, current load 6000 A – 15000 A

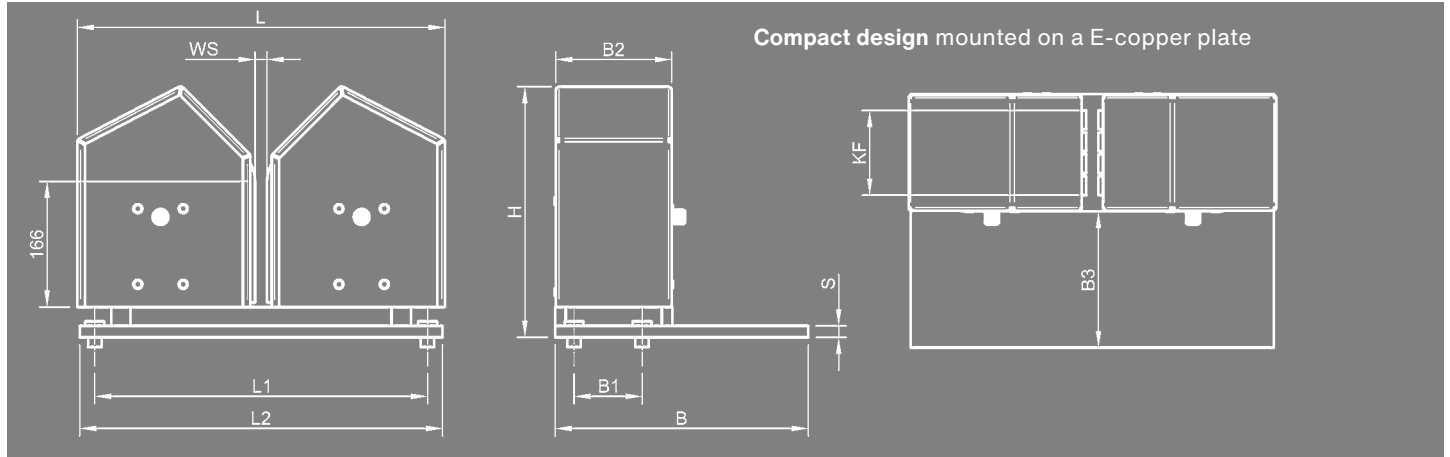

Part-No.	current load	dimensions mm										weight
		L	L1	L2	B	B1	B2	B3	H	S	KF	
25553	6000 A	486	440	480	335	1 x 90,0	153	180	331	15	112	118 kg
25554	8000 A	486	440	480	364	2 x 67,0	182	180	331	15	141	133 kg
25555	10000 A	486	440	480	452	2 x 96,0	240	210	336	20	199	185 kg
25556	12000 A	486	440	480	481	2 x 110,5	269	210	341	25	228	210 kg
25557	15000 A	486	440	480	539	3 x 93,0	327	210	341	25	286	247 kg

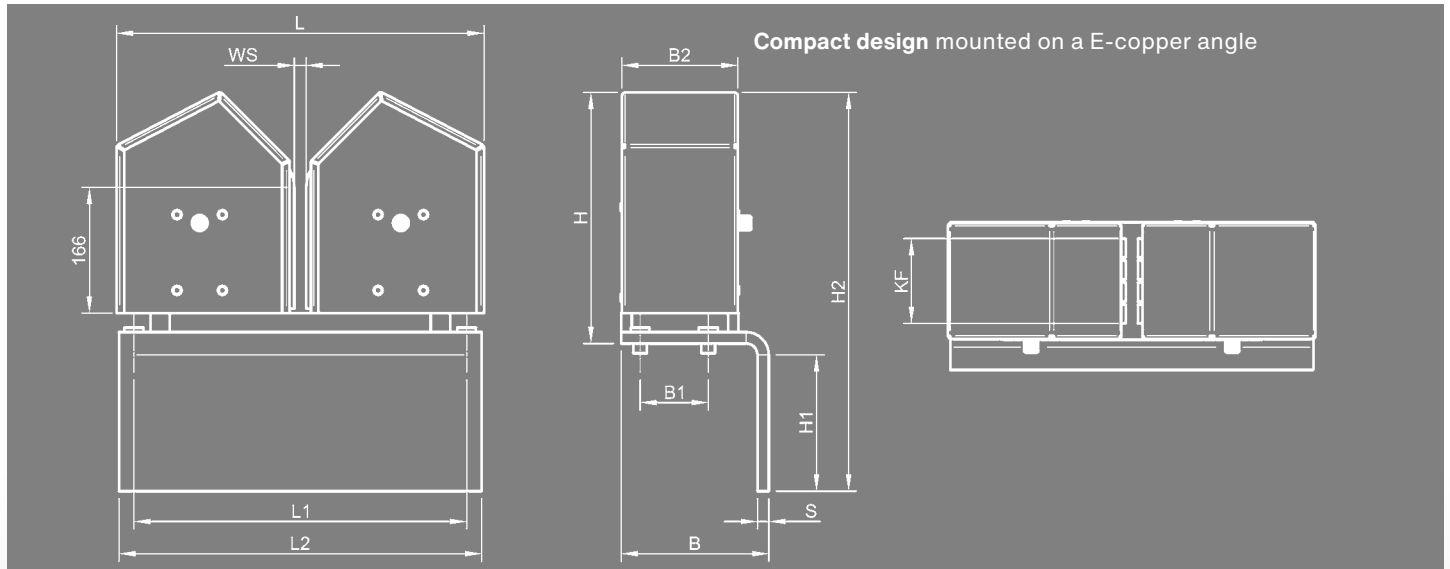

Part-No.	current load	dimensions mm											weight
		L	L1	L2	B	B1	B2	H	H1	H2	S	KF	
25653	6000 A	486	440	480	195	1 x 90,0	153	331	180	526	15	112	121 kg
25654	8000 A	486	440	480	234	2 x 67,0	182	331	180	526	15	141	137 kg
25655	10000 A	486	440	480	302	2 x 96,0	240	336	210	566	20	199	190 kg
25656	12000 A	486	440	480	331	2 x 110,5	269	341	210	576	25	228	218 kg
25657	15000 A	486	440	480	389	3 x 93,0	327	341	210	576	25	286	254 kg

The values in the tables based on a bus-bar thickness of 20 mm. When working with differing bars please notice that the width of the contact-saddles and if applicable the thickness of the E-copper plate or angle will be accordingly changed. Minimum height of the bus-bars 80/120 mm. When working with a height of 80 mm or less than 120 mm it is necessary to mount a equalizing piece in the middle of the contact-saddle. On demand all contact-saddles are deliverable with a additionally mounted temperature sensor Pt 100.

Control modules for pneumatically resp. hydro-pneumatically activated contact-saddles

These new developed control modules switch the needed air-pressure on or off automatically when working with hydro-pneumatically or pneumatically activated contact-saddles. The switching operation will be realized in the same moment when the current of the tank is switched on or off. With the new druseidt control modules you are able to use hydro-pneumatically or normal pneumatically driven contact-saddles on every place in your plant, without doing any intervention in your existing tank-control-system. Even when working with the control modul type II = Part-No. 36101 an installation of an external air-pressure-system is unnecessary.

A normal power outlet is sufficient. So it is possible to substitute e.g. spring activated contact-saddles, when they are actually overloaded, through hydro-pneumatically or pneumatically activated contact systems without problem. Or you can test hydro-pneumatically or pneumatically driven systems on one or more tanks without doing a costly rebuilding of the plant or the tank-control-system.

Druseidt control-modules enable

- a maximum of flexibility
- an optimizing of your contact systems to your demands
- a working without an external air-pressure-system (modul Part-No. 36101)
- an easy but extremely effective handling without problems

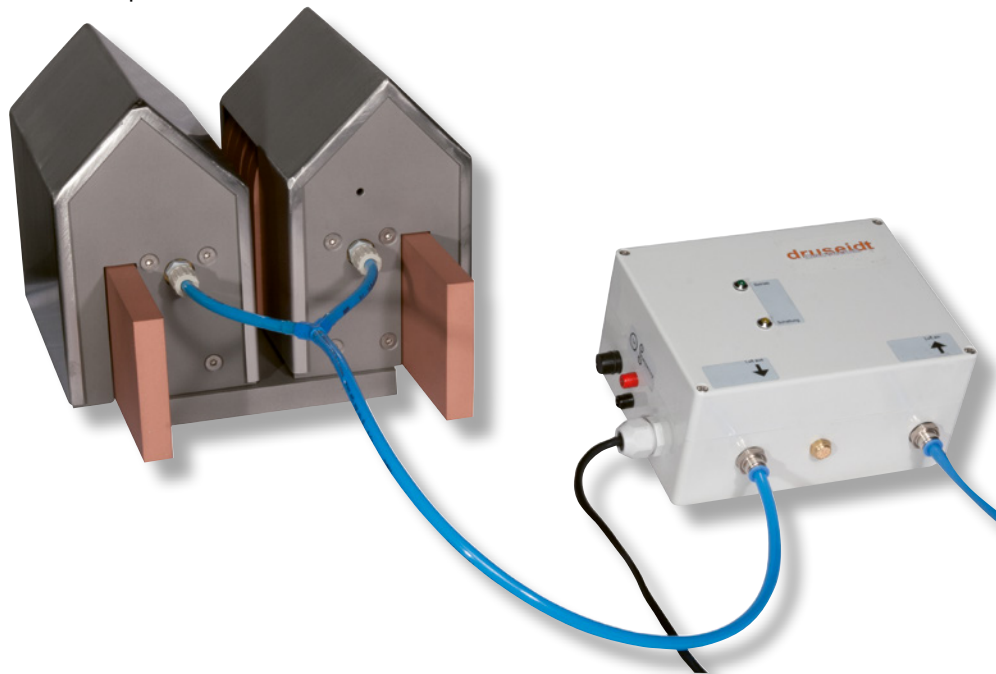

deliverable design

Part-No. 36100

design I: without integrated air pressure supply
(an existing air-pressure-supply is necessary)



Part-No. 36101

design II: with integrated air-pressure supply
(do not need any external air-pressure-supply)



Druseidt cleaning systems

an optimized completion when working with our high current contact-saddles

Druseidt cleaning systems and devices enable an extremely reduction of power losses and are destined to minimize the costs of repair and maintenance in order to optimize the process cycle.

So we deliver in standard design:

- Druseidt-hand-cleaning-slider for the fast cleaning of druseidt contact-saddles, also applicable in running processes
- Druseidt-cleaning-carriers for automated cleaning of contact-saddles, integrable in automatized production processes
- Druseidt-cleaning-saddles for automated cleaning of contact surfaces on product-carriers, integrable i. e. instead of non-powered support blocks at the non-conducting tanks

Soiled contact-saddles and contact surfaces lead to:

- **higher contact resistance**
- **higher power losses**
- **higher heating**
- **higher maintenance and repair costs**



Hand-cleaning slider for two hand operation



Hand-cleaning slider for one hand operation

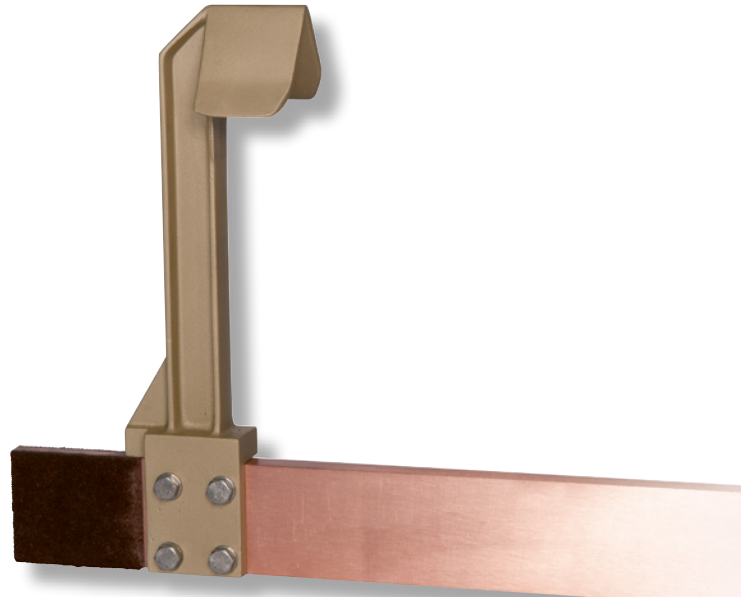

Cleaning-carrier

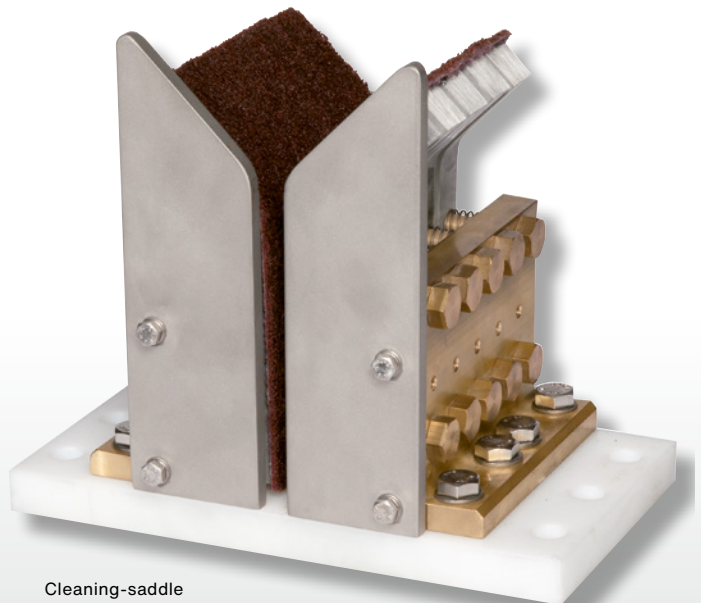

Cleaning-saddle

Druseidt hand-cleaning-slider and cleaning-carriers

We deliver hand-cleaning-slider in order to clean the contact surfaces of high current contact-saddles as well as contact surfaces of bus-bars or plates. So we offer:

Hand-cleaning-slider

Our hand-cleaning-slider allows a cost effective and efficient cleaning of the contact surfaces of our standard and similar contact-systems. They are adapted to the dimensions of the bus-bar thickness. In dependence of the space and the volume of the contact-saddles we deliver slider for one hand as well as two hand operation.

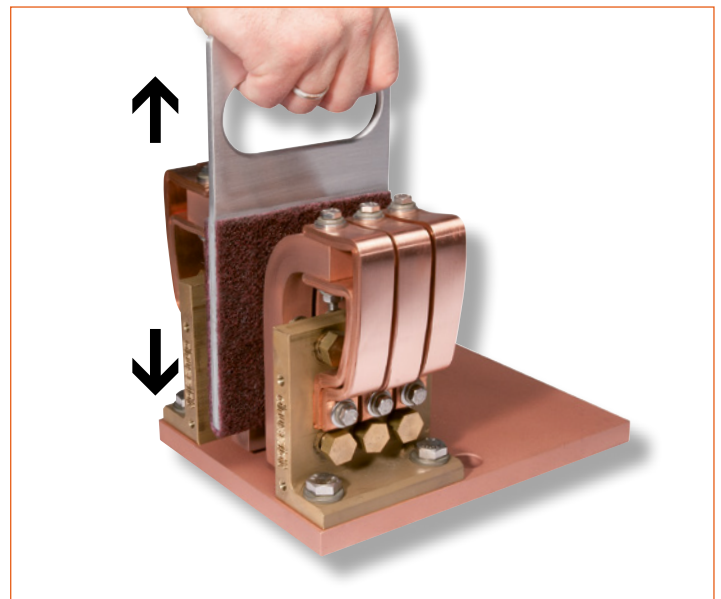

Cleaning procedure /one hand operation

Cleaning-slider/ one hand operation	Cleaning-slider/ two hand operation	for bus-bar thickness
Part-No.	Part-No.	
36030-10	36040-10	10 mm
36030-12	36040-12	12 mm
36030-15	36040-15	15 mm
36030-20	36040-20	20 mm
36030-25	36040-25	25 mm

Cleaning-slider for other bus-bar thickness as in the table on request

Cleaning-slider

Part-No. 36110

Cost effective and efficient device for simply cleaning of bus-bars and bigger contact surfaces.

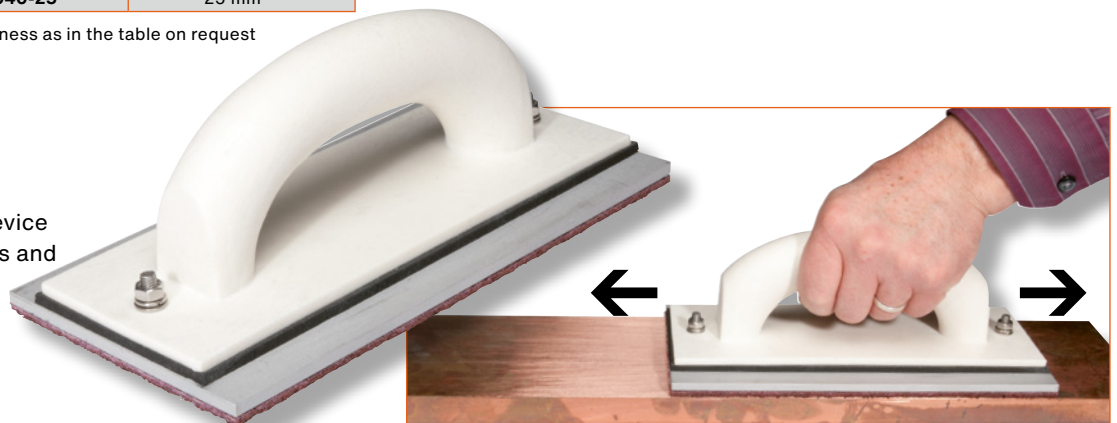

Cleaning procedure of bus-bars

Cleaning-carrier

In order to integrate the cleaning procedure of our contact-saddles in the automated process of your plant, we offer the production of individual designed cleaning-carriers according to your special requirements. Cleaning-carriers have an exchangeable mounted cleaning-part at the end of the carrier. The cleaning parts are coated with our special fleece and dimensional coordinated to your contact-saddles. In such way it is possible to integrate a cleaning cycle automatically in your process once a day, once per shift or any other interval. The surfaces of the contact-saddles will be cleaned by running-in and out of the cleaning-carrier for several times. So an optimized current transfer is guaranteed also in plants with higher material pollution. We are pleased to support you in rebuilding your existing plants as well as in the constructing of new plants.

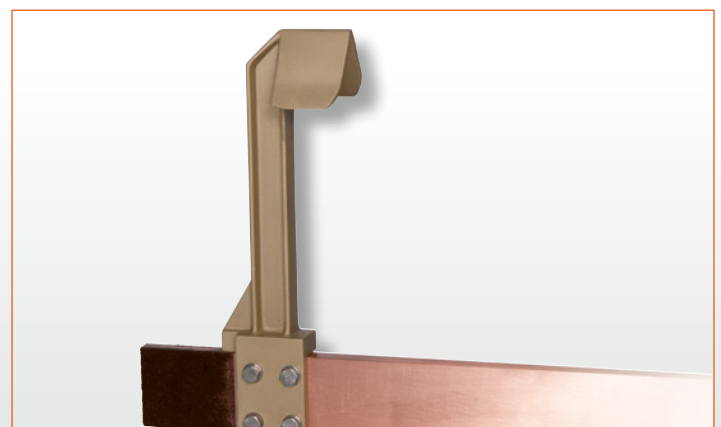

Cleaning-carrier

Cleaning-saddles for bus-bars and product-carriers

System description

Druseidt-cleaning-saddles based on the principle of our spring-activated contact-saddles. The cleaning surfaces are coated with our special cleaning-fleece. This special materials cleans the contact surfaces of the product-carriers by running-in and out. The fleece has a high chemical resistance and could be cleaned by using a compressed air pistol. Tests in laboratories and practice application show a long lifetime and good results of the cleaning process. In case of abrasion it is possible to change the saddle-halves easily.

The models in standard design are coordinated with the contact dimensions of our Titan system.

Additionally we manufacture cleaning-saddles coordinated with the dimensions of other contact systems as well as different contact length of product-carriers.

In order to guarantee an optimized cleaning effect we deliver all cleaning-saddles adjusted to the thickness of the bus-bars or product-carriers. Cleaning-saddles can be mounted instead of non-powered support blocks at the non conducting tanks. So they are integrated in the automated process-cycles of the plants.



druseidt-cleaning-saddles are characterized by an efficient cleaning effect and a good lifetime. They reduce power losses between contact-saddles and product carriers.

In an on-road-test it was proven, that druseidt-cleaning-systems have a very long lifetime and are easily to clean in order to reuse without losing its cleaning function. Combined with the new developed contact-system druseidt-Titan you are able to reach an optimum of efficiency for your plant.

Cleaning-saddles for product-carriers
 coordinated with the dimensions of our contact system Titan

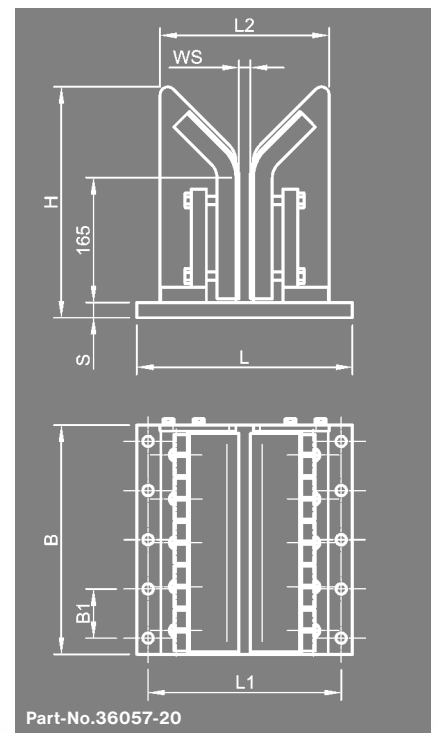
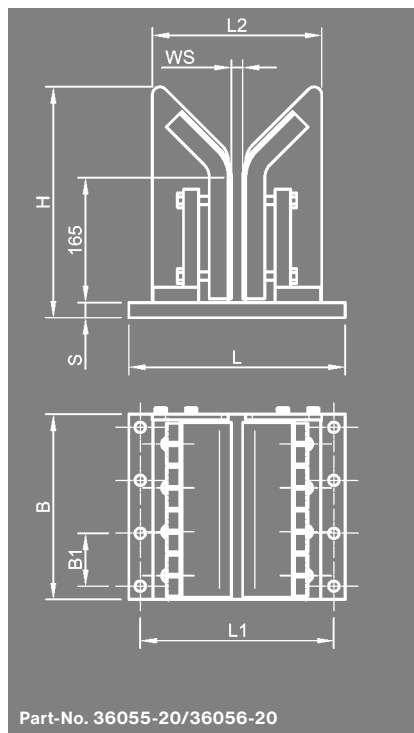
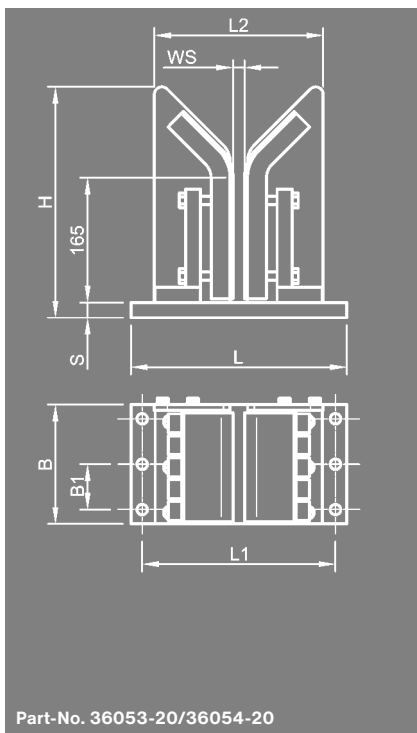
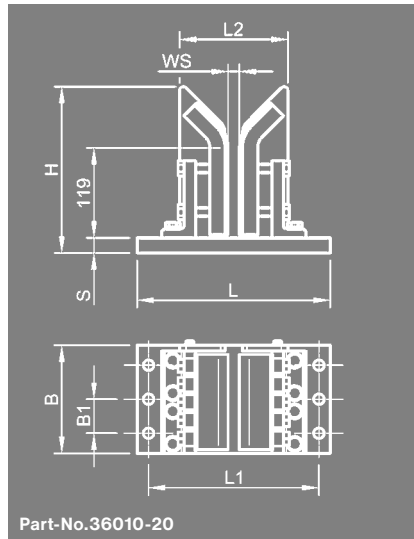
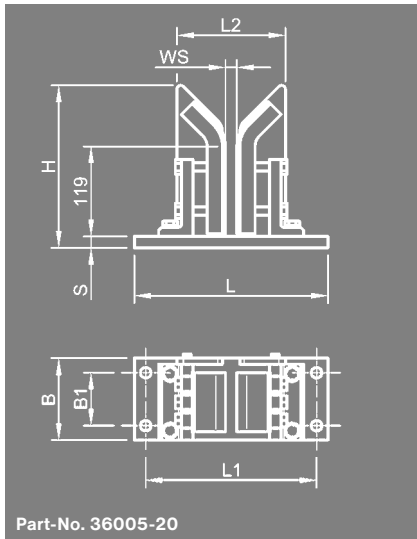

Part-No.		consistant with Titan-contact, current load	dimensions mm							weight
cleaning-saddle, complete	spare part/saddle half complete		L	L1	L2	B	B1	H	S	
36005-20	36005-A	3000 A	255	225	143	108	1 x 70	215	15	7 kg
36010-20	36010-A	4000 A/5000 A	255	225	143	143	2 x 45	220	20	10 kg
36053-20	36053-A	6000 A	285	255	233	129	2 x 45	305	20	16 kg
36054-20	36054-A	8000 A	285	255	233	158	2 x 60	305	20	19 kg
36055-20	36055-A	10000 A	285	255	233	216	3 x 60	305	20	25 kg
36056-20	36056-A	12000 A	285	255	233	245	3 x 70	305	20	28 kg
36057-20	36057-A	15000 A	285	255	233	303	4 x 65	305	20	34 kg

The values in the tables based on a bus-bar thickness of 20 mm. When working with differing bars please notice that the width of the cleaning-saddles will be accordingly changed. Additionally to the standard design we manufacture also cleaning saddles coordinated with the dimensions of other contact systems as well as different contact length of product-carriers.

Druseidt your partner for high current contact systems and accessories for anodizing and electroplating equipment

We offer more than the simply delivering of components for current-transmission e.g.:

- realization of a high quality standard
- reproduction of products and processes
- quick delivery of products
- flexibility to realize your special wishes
- extensive consultation and service performances
- constructional support by the realization of projects and products
- developing of new and further development of existent products
- extensive services, realization of repair and installation works, constructional solutions for plants and high current components, express deliveries of stocked standard material etc.

Our wide field of products for anodizing and electroplating plants:

- high current contacts and accessories for rack systems
- contacts for galvanizing racks
- contacts and accessories for barrel units
- highly flexible copper connectors
- designing and manufacturing of product-carriers
- designing and manufacturing of complete bus-bar systems
- contacts for rotating collectors
- heating and regulating devices
- switching units and mounting accessories



General advice

The measurements and technical information written in this catalogue have been determined with greatest care and are updated continuously in our documentation. We reserve us the right to make technical as well as changes of measurements, colours or formats after print. **Our information, especially the values for possible current-loads are not binding, they are only approximate values under optimized conditions. The relation between conductor cross-section and current-load fixed in national or international regulations are not cancelled through our information.** Only the values in our written order confirmations are binding for us.

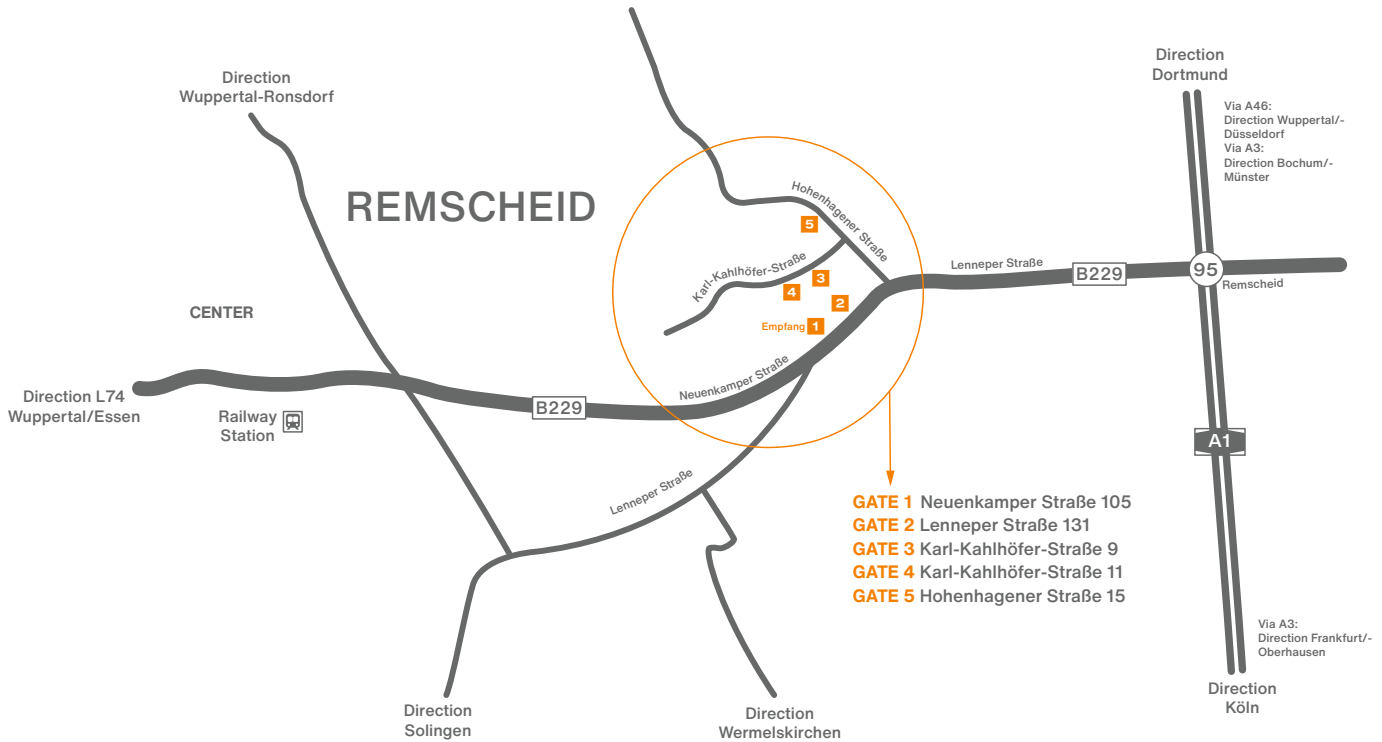

Paul Druseidt

Elektrotechnische Spezialfabrik GmbH & Co. KG

Neuenkamper Straße 105
42855 Remscheid - Germany

Phone: +49 (21 91) 93 52-0
 Fax: +49 (21 91) 93 52-150
 Web: www.druseidt.de
 E-Mail: info@druseidt.de

Monday - Thursday:
7:30 a.m. - 4:00 p.m.
 Friday:
7:30 a.m. - 12:00 p.m.

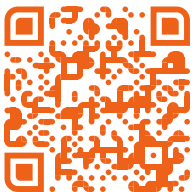

Visit our online shop and use the convenient product search as well as the convenient inquiry and ordering process..

Simply scan the QR code or enter it in your browser: shop.druseidt.de

Use our download area or order our special catalogues to the following subjects:

- „druseidt-Titan“ High current contact systems and cleaning devices (01/11)
- High current contact systems and cleaning devices type series up to 5000 A (02/11)
- Water cooled high current cables up to a cross-section range of 2000 mm² and high current pipe-systems (01/14)
- Water cooled high current cables preferably for electric arc- and ladle furnaces (02/14)
- Pneumatically actuated high current bolt contacts and switching units (01/18)
- Flexible power- and grounding connectors with welded contact areas (02/2018)
- Highly flexible silicone insulated cold- and heat resistant cables, ready assembled connectors (03/18)



DOWNLOAD